

MODELS	INPUT VOLTAGE	WATTS	HERTZ
TX6 & TX7	120VAC 230VAC	80	60 50/60

INSPECTION: Unpack the unit. Inspect the unit for external and/or internal damage. IF THE UNIT IS RECEIVED DAMAGED, FILE CLAIM WITH DELIVERING CARRIER. WE CANNOT FILE THE CLAIM FOR YOU.

NOTE: THE TEFLON TAPE COMES PRE-INSTALLED AT FACTORY, PARAGRAPHS BELOW ARE FOR INFORMATION ONLY

IMPORTANT: The packet attached to these instructions contains a special adhesive backed tape that is 1/4 inch wide and approximately 3 inches long. CUT THIS TAPE INTO 4 PIECES ABOUT 5/8 INCHES LONG.

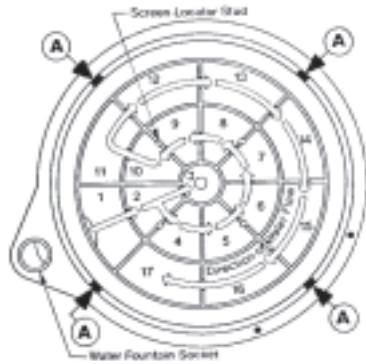

Referring to the illustration of the Turn-X base on the left, remove the adhesive backing on the pieces of tape and affix them securely (adhesive side down) to the bottom of the groove in the base at the 4 points identified by the letter A.

The tape is quite smooth and the dome will turn easily on it. If there are any burrs on the bottom edge of the dome, remove them.

The drawing on the left also shows the base compartments and direction of water flow. WATER FLOW IS PART OF THE UNIT HUMIDITY CONTROL and is discussed in the paragraph HUMIDITY REGULATION.

WARNING

Incubators are electrical devices and should be treated as such. Electrical repairs should be made by competent electrical service personnel. Disconnect or unplug the power before attempting repairs or cleaning the incubator.

GROUNDING: Certain metal and electrical parts of the incubator are grounded. You can identify these parts as they have a GREEN or GREEN WITH YELLOW STRIPED wire connected to them. Grounds are for your protection and should never be removed or tampered with.

POWER CORDS: All incubators and turners have three prong plugs on the power cord. The bottom round prong is a ground connection. It is through this connection that ground is provided for the grounded incubator parts. You should be sure that the outlet the power cord is plugged into is actually grounded. Using an ungrounded outlet or defeating the purpose of the ground by cutting off or removing the ground prong on the plug could, under certain situations, cause serious electrical shock when the parts are touched. Frayed or worn power cords should be replaced immediately.

ELECTRICITY AND MOISTURE: Moisture and electricity do not mix well and because electric incubators must be operated in conditions of high humidity for part of the incubation cycle, certain precautions should be taken. 1. Do not add water to the incubator until it reaches operating temperature. 2. Use distilled water only. 3. As soon as incubation/hatching is complete, remove all water from the unit and dry the area that had water on it. If the top of the incubator is removable, remove it from the base. Allow the top to air dry, if the top is left on or water is not removed, a high concentration of moisture is left in the incubator. As the incubator cools, excessive moisture will accumulate on electrical and metal parts causing deterioration of these components, failure of the electrical components can occur when the incubator is again used.

INCUBATOR ENVIRONMENT: The environment your incubator is used in can have a pronounced effect on your hatch. Improper environment can cause temperature and humidity control problems during the incubation cycle. For best results, incubators should be used in an area that has a controlled ambient temperature of 70° F. Operating incubators in less than 70° F ambient or in a room that has wide temperature variations can have a detrimental effect on the incubator's operation and it may be necessary to make additional and frequent temperature control adjustments during incubation. Incubators should not be located near heat or in direct sunlight. Avoid locations near windows or doorways or where drafts occur. Remember that the eggs must receive air, avoid locations where carbon dioxide concentration might be high, (i.e., near gas furnaces or hot water heaters).

THE INCUBATOR SHOULD BE BROUGHT TO OPERATING TEMPERATURE FOR 24 TO 48 HOURS BEFORE PUTTING EGGS IN IT. LET YOUR EGGS STAY AT ROOM TEMPERATURE FOR AT LEAST 12 HOURS BEFORE SETTING THEM IN THE INCUBATOR.

HUMIDITY AND ITS CONTROL: There are two very important things you should know about humidity and its control. 1. You control humidity - the incubator can't. As the incubator operator, you set the temperature desired and you determine by adjusting the amount of water surface exposed to the heated air what the humidity in the incubator will be. 2. The wet bulb thermometer reading is not the percent of humidity in the incubator. To give you an example of this: if the incubator dry bulb thermometer reads 100°F, and the wet bulb thermometer reads 84°F, the humidity in the incubator is 51%, not 84%. The hatching manual shipped with your incubator describes how to determine humidity in detail. You should read the section on humidity and calibration thoroughly. Always use a new wick or carefully clean an old wick each time before the incubator is used.

INCUBATOR CLEANING: Clean the incubator as soon as you are done using it. DO NOT WAIT UNTIL YOU NEED TO USE IT AGAIN. Using a low velocity vacuum, remove as much dust and dirt as possible. You may use a mild soap with water to clean all the parts or a weak solution of ammonia and water. Wipe the incubator clean with a cloth coated with the cleaning solution. BE SURE THE ELECTRICAL POWER TO THE INCUBATOR IS DISCONNECTED OR UNPLUGGED BEFORE ATTEMPTING TO CLEAN THE UNIT. Avoid getting liquids on the temperature controller, heater coil and the coil insulators. When cleaning is complete, allow the incubator to dry completely, then cover it in storage until it is used again.

INCUBATORS ARE ELECTRICAL DEVICES AND SHOULD BE TREATED AS SUCH. ELECTRICAL REPAIRS SHOULD BE MADE BY COMPETENT ELECTRICAL SERVICE PERSONNEL. DISCONNECT OR UNPLUG THE POWER BEFORE ATTEMPTING REPAIRS OR CLEANING THE INCUBATOR. **PLEASE READ ALL INSTRUCTIONS CAREFULLY AND COMPLETELY BEFORE ATTEMPTING TO OPERATE THE INCUBATOR.**

THE INCUBATOR SECTIONS

The incubator consists of five sections; the dome assembly, the egg turning ring assembly, the screen, the base plate and the water fountain.

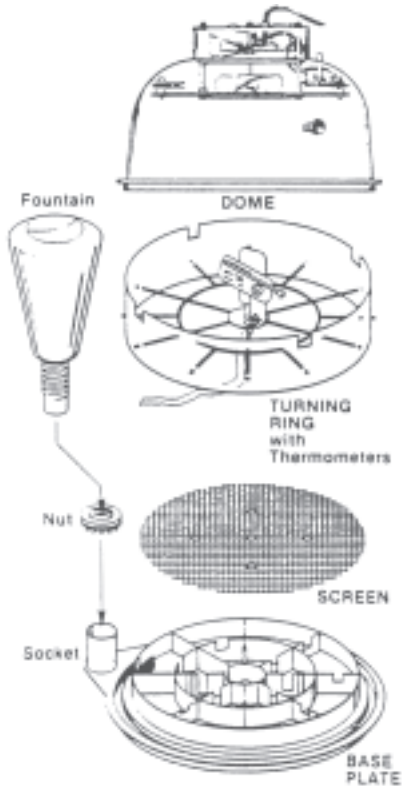

An efficient egg hatching machine is formed when the five sections are properly mated together.

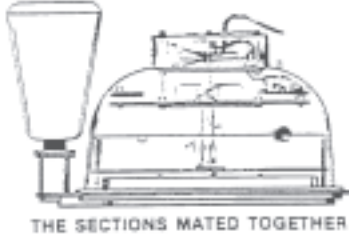

The incubator is pre-assembled at the factory.

This information is provided for reference.

ASSEMBLING THE INCUBATOR

Assemble the turning ring. Remove the plastic film from the strap. Hold the plastic strap with notched side UP and insert the spokes of the turning ring into the strap until it completely surrounds the turning ring. Fasten the ring using the brads and washers supplied, form the assembly into a circle. Now mount the thermometer/hygrometer assembly. To assemble, carefully follow instructions attached to your assembly packet. Units shown on this page show the TX-6 carded thermometer/hygrometer assembly.



Before the screen and turning ring are positioned on the base, these two parts should be held together with the wick through the center hole in the screen and pulled out full length below. With the screen and turning ring against each other and the wick dangling below, place the assembly on the base with the wick extending toward the water fountain socket and laying through the two slots in the water segments of the base. The wick must extend in the base toward the fountain in order to be wet immediately when water is introduced into the first segment adjacent to the fountain

Fit the four holes in the screen over the extrusions on the base and press into place. When the dome is set on the base, notice that the screws through the wall engage in slots in the top of the plastic turning ring strap. These screws project inside through the dome from the two knobs outside. Proper seating of the screws in the turning ring strap will put the dome in gear with the turning ring assembly, and thereafter rotating the dome on the base plate will cause the egg turning ring to move also. See the drawing below. When eggs are in the incubator, they will be positioned between the spokes of the turning frame and will be rolled over when the dome is turned on the base. Rotating the dome from the outside moves the egg turning ring inside and turns the eggs over. This is another advantage of the Turn-X system. . . to turn the eggs without opening the incubator.

Turning ring and strap assembly has been pre-assembled at Lyon.

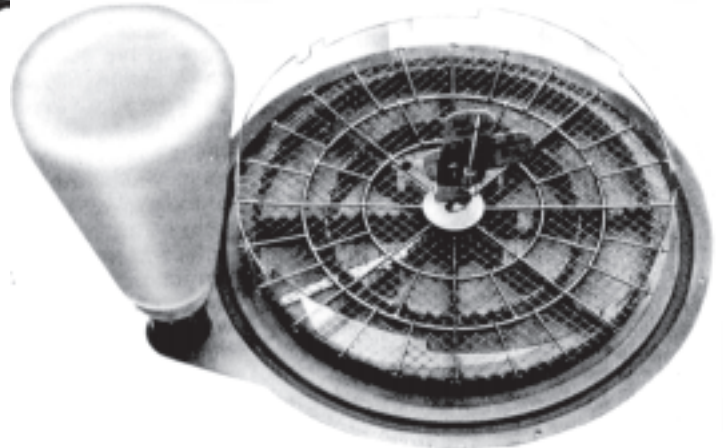
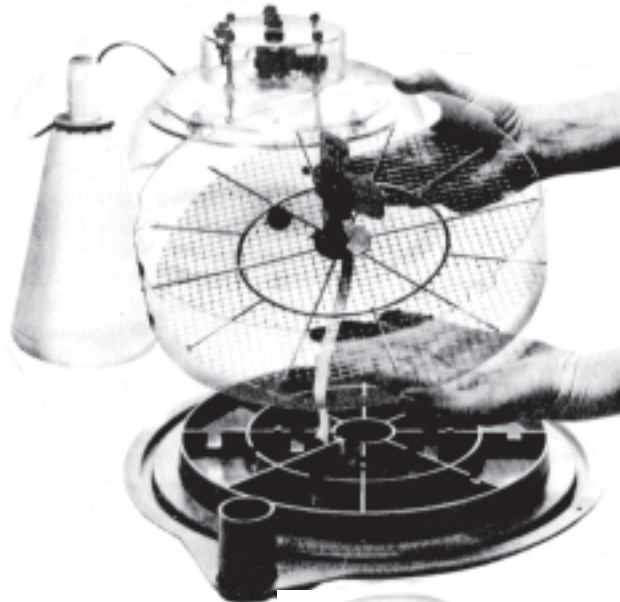

GETTING THE INCUBATOR READY

With the incubator sections correctly assembled as per the foregoing explanations, and being sure that the wick is laying under the screen through two slots in the base and is extended outward toward the fountain, plug the electrical cord into a wall socket. The fan will begin spinning and the heater will come on, indicated by the small light.

TEMPERATURE REGULATION

The incubator was regulated before it was shipped to you. Due to handling in shipment, it may require further adjustment. Watch the thermometer as the temperature builds up. The indicator light should go off at 100°F. After that, the light will go on and off at short intervals. This on and off of the indicator light and a constant thermometer reading of 100°F indicate the thermostat is controlling the heat. The thermometers should be inspected many times for several days to be sure the temperature is fully stabilized.

TX-6 TEMPERATURE ADJUSTMENT: The TX-6 has a solid state temperature control. The regulator shaft protrudes through the dome above the thermostat board. Turning the shaft **CLOCKWISE** will increase the heat, turning the shaft **COUNTERCLOCKWISE** will lower the heat. In regulating the thermostat, turn the shaft slowly and carefully.

TX-7 TEMPERATURE ADJUSTMENT: The TX-7 has a 10 turn solid state temperature control. This control is designed to operate the incubator in a range of 80 to 106°F. Each 360 turn of the control covers a range of approximately 2 - 3°F for precise temperature setting.

When tested at the factory, the control was set at 100°F. To **LOWER** the Temperature turn the control knob to the **LEFT** and to **INCREASE** the temperature turn the knob to the **RIGHT**. Remember that a **COMPLETE 360 TURN** of the potentiometer covers only 3°F. Make small adjustments to the temperature desired.

REGULATE THE INCUBATOR AT:
100°F for temperature and 86°F (wet bulb) for humidity (for chicken eggs).

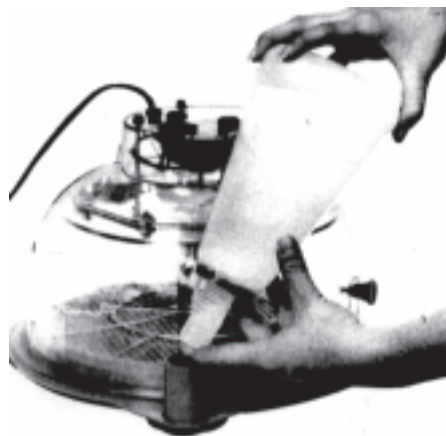

HUMIDITY REGULATION

With the nut on the neck screwed against the body of the fountain, fill the fountain with water. Place a finger over spout to prevent spilling and invert the fountain over the socket on the base. Remove the finger and quickly slide the spout to the bottom of the socket. Water will immediately gurgle into the base segment adjacent to the fountain. Capillary attraction will soon wet the entire wick up to the thermometer, after which the wet bulb will register humidity. With the fountain in place and the incubator running at 100°F, humidity may stabilize inside the incubator in about five minutes. A humidity reading may then be made. Unless the incubator is in a very humid climate adjustment to increase the humidity will be needed. With the fountain remaining in place in the socket on the base, more water is introduced into the base by holding the nut on the fountain neck and turning the fountain counterclockwise a half turn. Read the wet bulb again and adjust the fountain upward again if it is needed. Continue to adjust the fountain upward in slow steps until the reading of 86°F is obtained.



Humidity accumulates in the incubator from evaporation in direct proportion to the surface area of water in the base. Each counterclockwise half turn elevates the fountain 1/16 inch and causes water to run into another cup Segment of the base. Dry climates require water in more cups than humid climates. Continually elevating the fountain will eventually run water into all seventeen cups. The object in humidity regulation is to determine what the elevation of the fountain and the number of cups with water should be for your climate. Watching the wet bulb thermometer while elevating the fountain half a turn at 3 to 5 minute intervals will eventually produce the desired reading of 86°F.

If hard, mineralized water is used, the wick may become clogged in a number of days, before this happens, you will have arrived at a satisfactory adjustment. Before each hatch, a new wick may be installed or the old one may be removed and washed to remove the materials that may have stiffened it. The use of distilled water in the fountain will largely eliminate the problem of mineral clogged wicks.

WHY EGGS ARE TURNED

It is necessary to turn incubating eggs for the very same reason a person turns himself while sleeping. That is, to relieve the pressure that restricts the nerves and impairs circulation. The mother hen on the nest instinctively beaks and turns the eggs at intervals. Developing embryos in the eggs will not grow in vigor and strength unless they are turned at regular intervals. Lack of turning may cause chicks to have paralyzed feet, crooked toes or to be so weakened as not to be able to escape the confines of the shell at hatching time. Any interval of turning longer than three or four hours gets declining results according to scientific studies. The longer the wait after four hours, the weaker the chicks may be.

POINT EGGS TO CENTER

Eggs are set in the turning ring with the small ends pointing to the center.

THE DEGREE OF TURNING

Ideally, eggs would be turned 180 degrees. That is, the side that is up before the eggs are turned will be down after they are turned. Generally, however, varying sizes of eggs cause some to be rolled more than others. With automatic turning when the eggs are moved once an hour, experience shows that it makes little difference if some eggs are turned more and others less.

An "X" may be marked on one side of several eggs and an "O" on the other side for visually indicating the movement of the eggs in the turning ring.

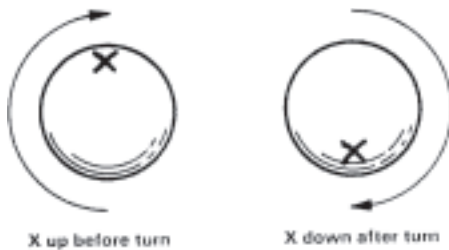

EGG TURNING DIAGRAM

Turning should start on the first day of incubation and be discontinued one day before hatching of 16 day eggs and two days before hatching of eggs that take 21 days or longer to hatch.

MANUAL TURNING SCHEDULE

A reasonable egg turning schedule and one that has proven to be successful is to turn the eggs the first thing on arising in the morning; beginning at 6:00 a.m. ; mid morning - approx. 10:00 a.m.; mid afternoon, approx. 2:00 p.m.; again at 6:00 p.m. and when you retire for the night, approx. 10:00 p.m. This is five times per day. Hatches have been produced with three turns a day or even with only two turns, but in general the percentage is low and the chicks do not survive well.

AUTOMATIC TURNING

Automatic turning is a far more successful method of hatching eggs. An automatic turner does not forget, it does not want to go away on the weekends and it turns day and night at set intervals. Most automatic turners are set on the basis of one movement each hour.

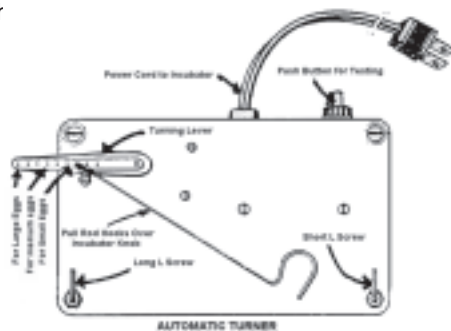

The automatic turner turns the eggs once each hour. Embryos in the eggs rest and grow during the periods between turns. Each turn lasts for 30 seconds during which time the eggs are gently rolled over.

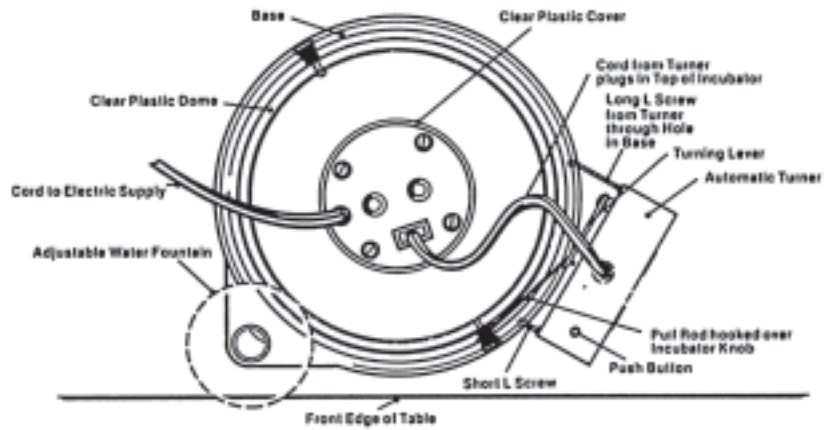

TOP VIEW OF INCUBATOR WITH AUTOMATIC TURNER

The turner sits at the right side of the incubator. The incubator and turner are attached together by two L shaped screws in the lower corners of the turner case. The short L screw must be in the front corner and the long L screw in the rear corner of the turner. Study the top view of the incubator and automatic turner on page four. The turned up ends of the L screws engage through two holes in the rim of the incubator base. The turner pull rod hook over a knob on the side of the incubator.

The automatic turner pulls and pushes the dome back and forth on the base. It is necessary that the two screws project inside the dome wall from the knob engage two slots in the top of the turner ring strap, (refer to the drawing).

POSITION OF EGGS

An incubating egg should be set in a normal position as it would on a flat surface; that is with the large end slightly higher than the point. An egg that persistently has the small end elevated may cause the embryo to be misoriented with the head toward the small end. In this misoriented position the chick is likely to drown when pipping. Therefore, it is quite important that the large end of the eggs should be slightly higher than the small ends, or as they would lie naturally on a flat surface.

THERMOMETERS AND WICKS

Having several spare thermometers and wicks is good insurance. Glass thermometers are easy to break and certain accidental circumstances may cause the spirits to separate. Having extra thermometers for comparison against each other will lead to accuracy.



EGG HATCHING TIME

BREED	HATCH
Coturnix Quail	16 days
Bobwhite	23 days
Pheasant	23 days
Chukar	23 days
Bantam	21 days
Chicken	21 days
Duck	28 days
Turkey	28 days

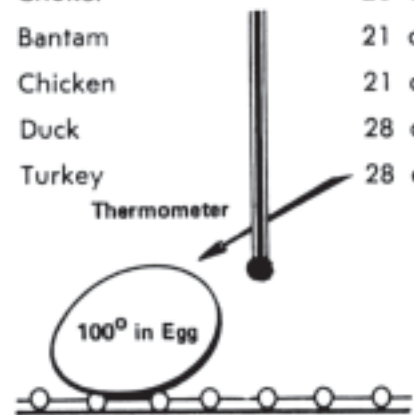

1690 Brandywine Ave.
 Chula Vista, CA 91911
 Telephone (619) 216-3400
 Fax (619) 216-3434
 www.lyonelectric.com
 e-mail: lyonelec@cts.com

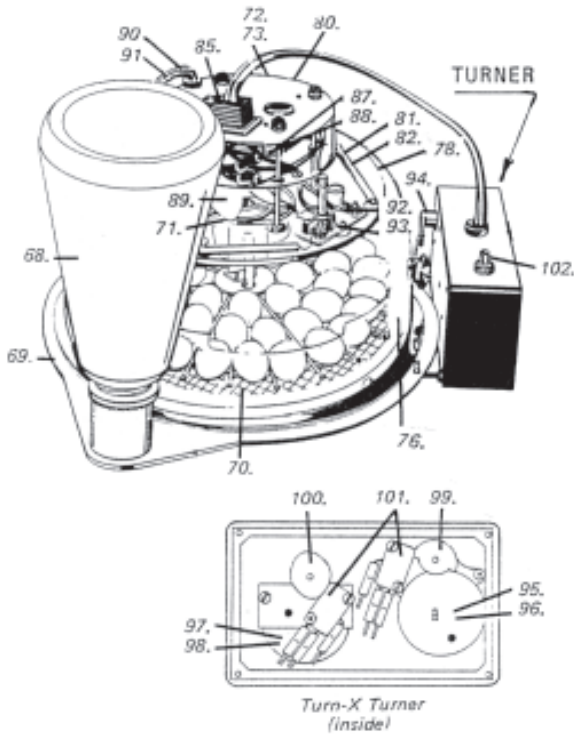

Types Of Egg Turning Rings

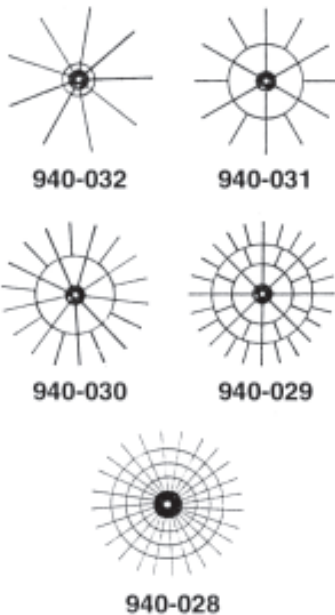

REPLACEMENT PARTS FOR TX-7 & TX-6

NO.	TX-7 Catalog Number	TX-6 Catalog Number	ITEM DESCRIPTION
68	350-005	350-005	Water Fountain
69	350-006	350-006	Base
70	130-001	130-001	Screen
71	350-016	350-016	Fan Guard (For older Units)
72	115-020	115-006	120V Wired Dome Assy.
73	115-021	115-007	230V Wired Dome Assy.
76	350-071	350-007	Plastic Dome
78	350-028	350-028	Plastic Baffle Plate
80	350-009	350-009	Plastic Motor Cover
81	270-012	270-012	224 OHM Heating Coil (120VAC)
82	270-013	270-013	432 OHM Heating Coil (230VAC)
85	200-049	200-049	Square Receptacle
87	320-073	320-073	120V Fan Motor
88	320-074	320-074	230V Fan Motor
89	320-075	320-075	3" Fan Blade
90	118-000-1	118-000-1	120V Power Cord
92	220-012	220-010	120V Thermostat Control
93	220-013	220-011	230V Thermostat Control
	500-013	500-009	Therm./Hygro. Assy.
	500-011		5 1/2" Mercury Therm. (2 Used)
		500-008	Carded Thermometer (2 Used)
	WK1-9		Wick Material, 9" Long
		WK2-6	Wick Material, 6" Long
	PCS1	PCS1	Wick Cinch Strap

REPLACEMENT PARTS FOR AUTOMATIC TURNER

NO.	CATALOG NUMBER	ITEM DESCRIPTION
94	320-097	Turning Lever & Rod Assy.
95	320-071	120V Power Motor
96	320-072	230V Power Motor
97	320-076	120V Timer Motor
98	320-077	230V Timer Motor
99	350-002	Power Motor Cam
100	350-000	Timer Motor Cam
101	460-020	Sensitive Snap Switch
102	460-019	Push Button Switch

EGG TURNING RINGS FOR TX-7 AND TX-6

CATALOG	ITEM DESCRIPTION
940-028	72 Combo Ring
940-029	48 Quail or Similar
940-030	27 Pheasant or Similar
940-031	18 Chicken or Similar
940-032	9 Goose or Similar